



Fall Foliage Placemat 18½" x 11½"

kidgiddy.com Copyright 2019 by 2 is Beautiful, LLC



some giddy to your life



kidgiddy.com

Fall Foliage Placemat Tips

1. This Fall Foliage Placemat pattern includes 3 different blocks that allow you to create a variety of placemat options for your fall or Thanksgiving table. If you are new to Foundation Paper Piecing, please read through all of the instructions, tips and tricks, as well as the accompanying tutorial on WeAllSew.com before beginning.
2. Leave all paper pieces attached in the leaf blocks until place mat top is completed. If you have removed the paper already, glue basting the sashing can help prevent stretching of individual pieces that have been sewn on the bias to prevent the distortion of the fabrics.
3. To minimize sashing fabric from stretching, sew right sides together with the sashing piece on the bottom.
4. After sewing each piece of sashing, press the sashing (open seams if not glue basted or inward toward darker sashing fabric) as preferred and trim accordingly.

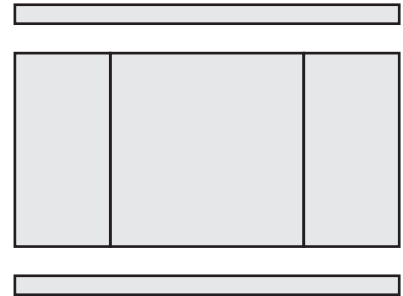
Placemat Assembly

1. Place the Sugar Maple Leaf in the center. Sew the Oak leaf to the right and the Beech & Acorns to the left of the Sugar Maple Leaf. (Fig 1) *(If you are sewing a placemat without some of the blocks - all panels will be 4 1/2" or 9 1/2" wide x 9 1/2" high. The final placemat, in any combination, should be 18 1/2" wide x 9 1/2" high.)*
2. Sew a 1 1/2" x 18 1/2" border print strip on both top and bottom edges (Fig 2).

FIG 1

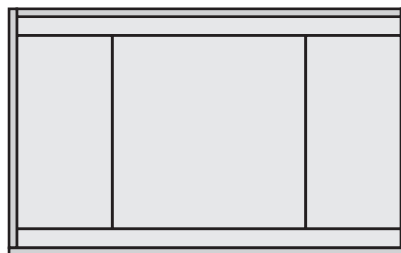


FIG 2



3. Carefully remove the paper pieces from each block. Use sharp tipped tweezers to get tiny pieces out of hidden seam allowances and tiny patches.
4. Press (and starch as desired) placemat top from both sides, first from the back to press seams, checking for any missed seam trimmings or tiny pieces of paper, especially in the corners.
5. Layer placemat top, batting and placemat backing. Baste and quilt as desired.
6. Square up and trim placemat edges.
7. Cut binding (yardage is based on crossgrain binding not bias binding) to 2 1/2" wide strips. Sew strips together on the bias to make approx. 70" of binding (extra is added for using a binding tool).
8. Fold binding as single or double fold and sew binding to quilt using preferred method.

FIG 3



Foundation Paper Piecing Overview

Unlike traditional piecing, foundation paper piecing is created by sewing on the printed lines with the fabric placed underneath the paper. Blocks can have one single section or multiple sections sewn together. Each section starts with a letter, followed by numbers which are sewn in numerical order. If the block has multiple sections, sew each section as instructed and follow the steps provided to connect the sections in sequential order.

Prep:

1. If your block has multiple sections, start by cutting apart your block sections using paper scissors.
2. Press fabric as needed (starch and press as desired).

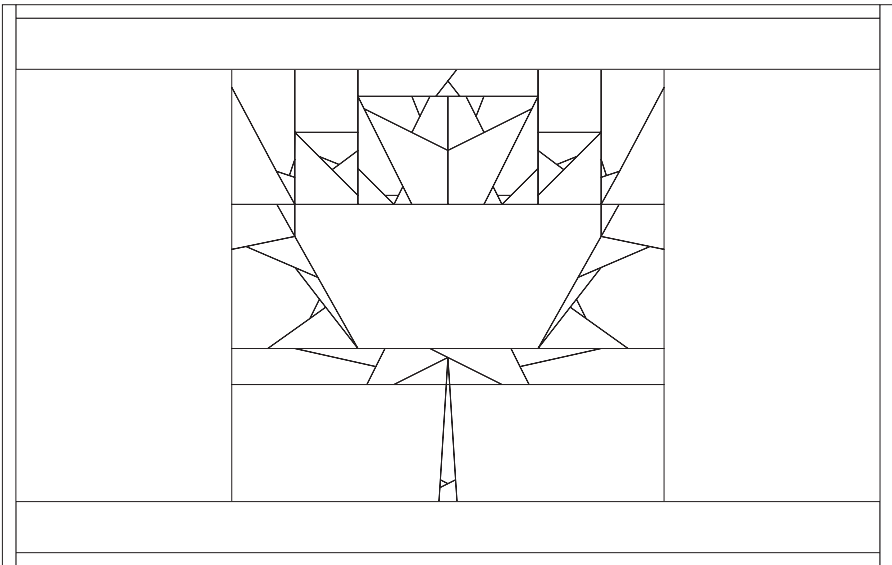
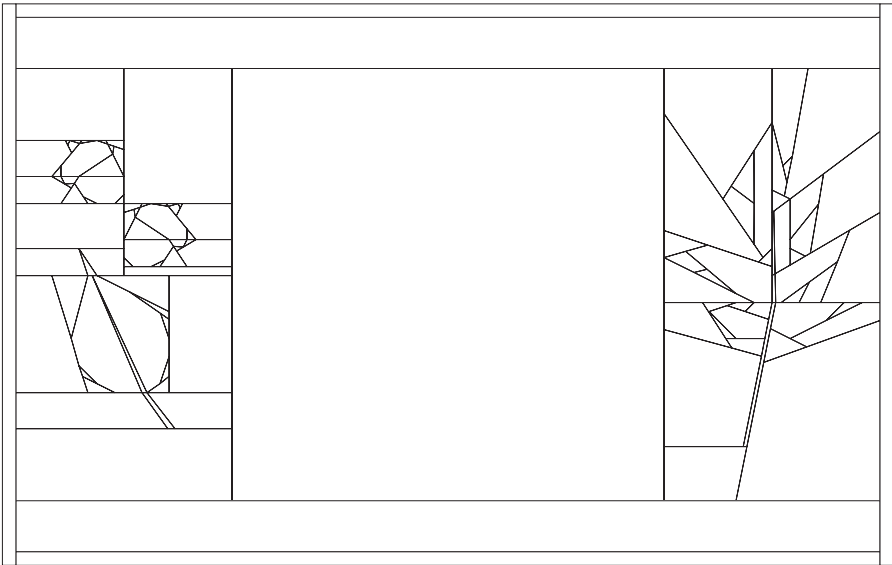
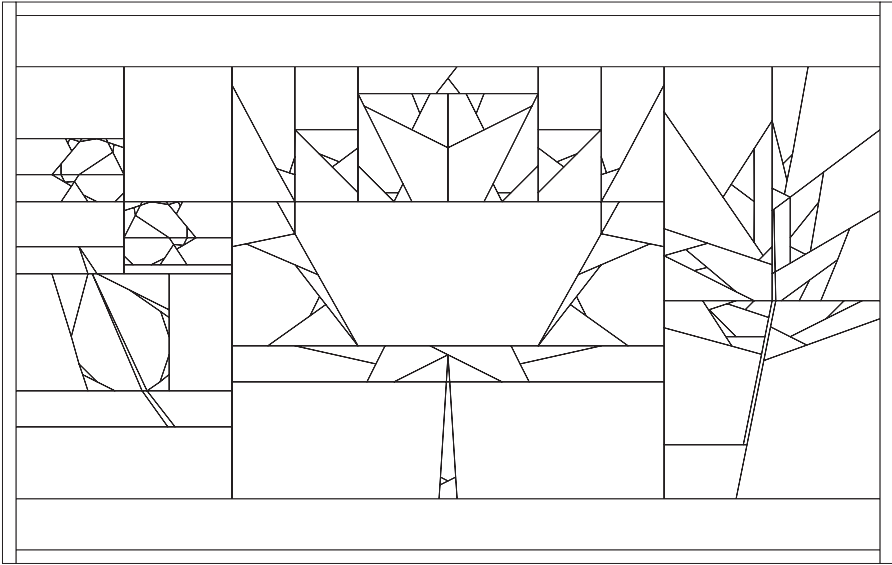
Sew:

1. Start sewing paper piecing section A, by placing fabric piece #1 underneath the paper piece area #1. The paper design is face up while the fabric is face down underneath. Use a strong light or light box to align your fabric accordingly.
2. Place the fabric for area #2 right sides together to the first piece (under the paper), making sure you have a sufficient seam allowance (1/4" or more) on all sides for both fabrics.
3. Sew the first line between area #1 and #2 without shifting the fabric and paper when placing under the sewing foot. Trim off excess seam allowance.
4. Press fabric open for area #2 using a mini iron or seam pressing tool.
5. Place fabric for area #3 right sides together. Stitch in place following the line, trim seam, press fabric open.
6. Continue with all pieces of section A until completed. Finish by pressing completed section on fabric side and trimming the 1/4" seam allowance. Repeat steps 1 - 6 until all sections are sewn.
7. Sew all sections together accordingly, press and trim the final block with a 1/4" seam allowance.

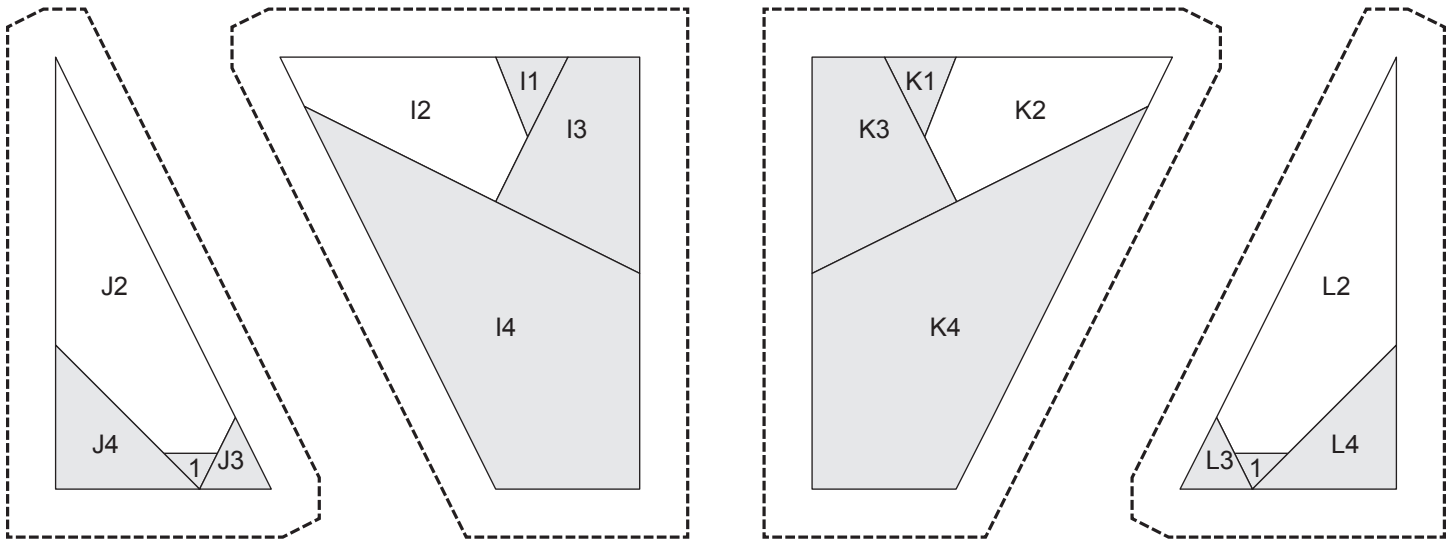
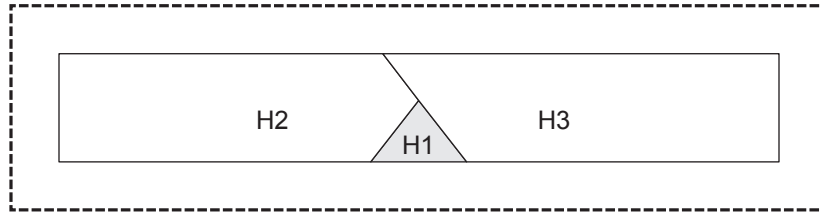
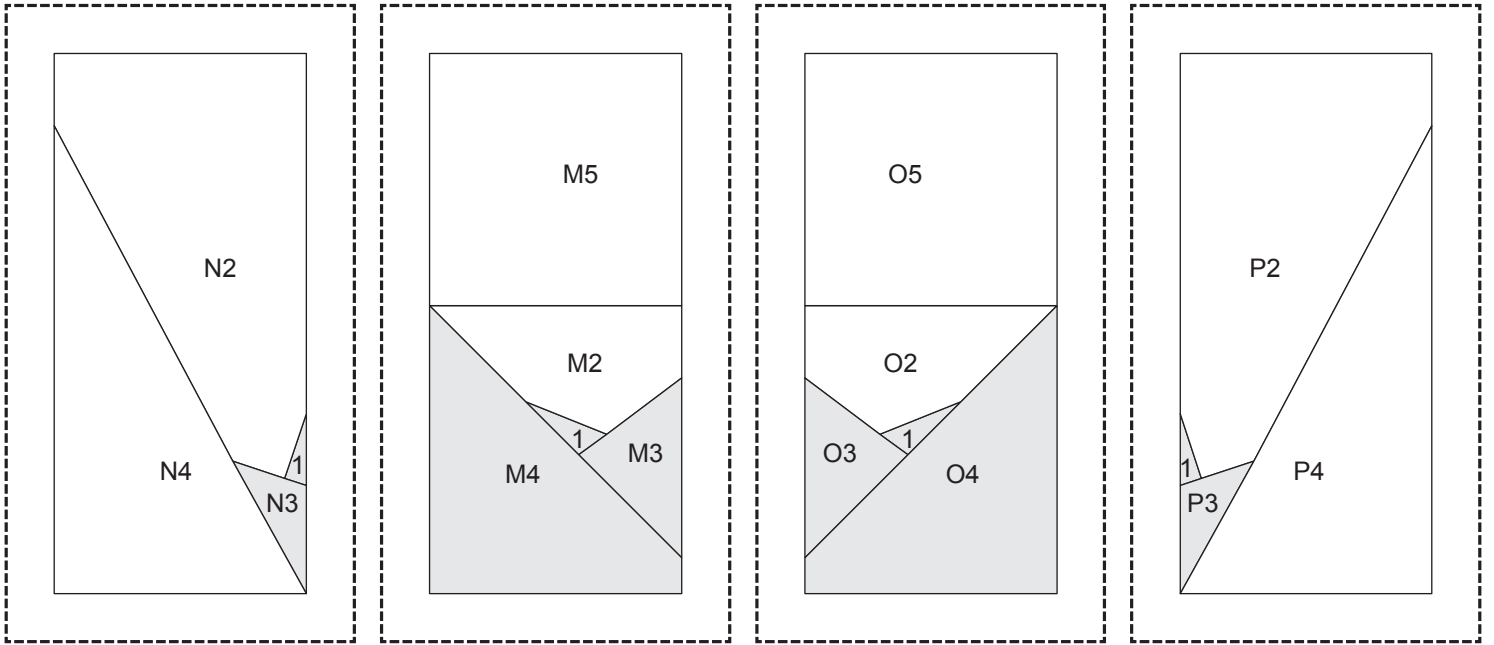
My Paper Piecing Tips

1. In paper piecing, you are only going to be sewing on the paper. While sewing, the paper will always be facing up so you can clearly see the colors and alpha/numerical sequences. Leave a little extra paper around the block to make trimming the block easier when finished.
2. Please be sure your printer prints to scale using the 1-inch mark on the pattern page. If it does not measure 1", adjust your printing options according to your owner's manual so all of the blocks will be accurate when completed (if you are using a photo copy of your original or a printed computer block).
3. You can precut all your fabrics (for every patch) prior to sewing, but I personally don't. I will precut large pieces, to ensure I use my fabric in the most economical way and reduce waste.
4. Use an older 80/12 needle. Paper piecing is a great way to use up older needles that are not perfectly sharp. Avoid using a damaged needle.
5. Shorten stitch length; I normally sew with a 2.4 stitch length and sew with a 1.8 stitch length when paper piecing. This makes paper removal easier once finished, without damaging seams.
6. Do not pre-fold each line on the paper sections (some people do this, but I find it weakens the paper preventing second chances if the fabric is not placed correctly).
7. When sewing blocks with multiple sections, first sew the sections with the larger fabric pieces if you might be short on a specific fabric.
8. Always use generous pieces as you are sewing and be mindful of directional prints and seam allowances. Always save your smaller pieces to use for smaller patches.
9. Sew 1/4" of an inch beyond the start of the line and 1/4" beyond the end of the line. This prevents the seam from coming undone while handling.
10. There is no need to lock in stitches when starting or stopping a seam. I prefer to stitch 2-3 stitches before the line starts and after the line ends. This prevents the actual stitch line from coming undone when trimming, especially along the edge into the seam allowance.
11. After each stitch, be sure to trim excess fabric leaving a clean 1/4" seam allowance. When sewing large pieces or thinner fabric, a slightly larger seam allowance is acceptable, as is a 1/8" seam allowance when there are tiny pieces to reduce bulk.
12. When sewing diagonal sections together, line up seam allowances where necessary, using pins or clips, from the back of one piece into the front of the other piece where they need to match. Sew a basting stitch (use a longer stitch length initially to verify the alignment of the pieces. When satisfied, sew the seam again with a shorter stitch length.) Using a longer stitch length will make it easier to unstitch the top and bottom if the alignment is off.
13. When an individual block section is only 1 large piece of fabric, I prefer to use a little dot or dab of washable glue to adhere the paper to the fabric, lightly pressing on the fabric side. This will prevent the fabric and paper from shifting when sewing section pieces together. Avoid using too much glue as it will not tear away easily when removing the paper. Only trim the first side that will be sewn to the other section. Trim other sides as needed. If you trim all sides at once, the piece may be slightly smaller than needed.
14. Be sure to press each section prior to trimming. Trim each section to 1/4" seam allowance as completed. Completed block should also be trimmed to 1/4" seam allowance.
15. Press blocks when finished prior to squaring up the block. Do not remove papers until the entire quilt top is finished.
16. My best tip for sewing foundation paper piecing blocks when first starting is to remember how you would sew the fabrics together if the paper were not there. I have taught many people how to sew FPP, and this tip lessens the confusion the piece of paper creates. Just because the paper is there doesn't mean you sew the two pieces together differently. You still put your pieces of fabric right sides together, and you most often will line up your raw edges (unless you are fussy cutting a specific portion of the fabric design). The paper is merely there to guide your sequential and straight stitching.

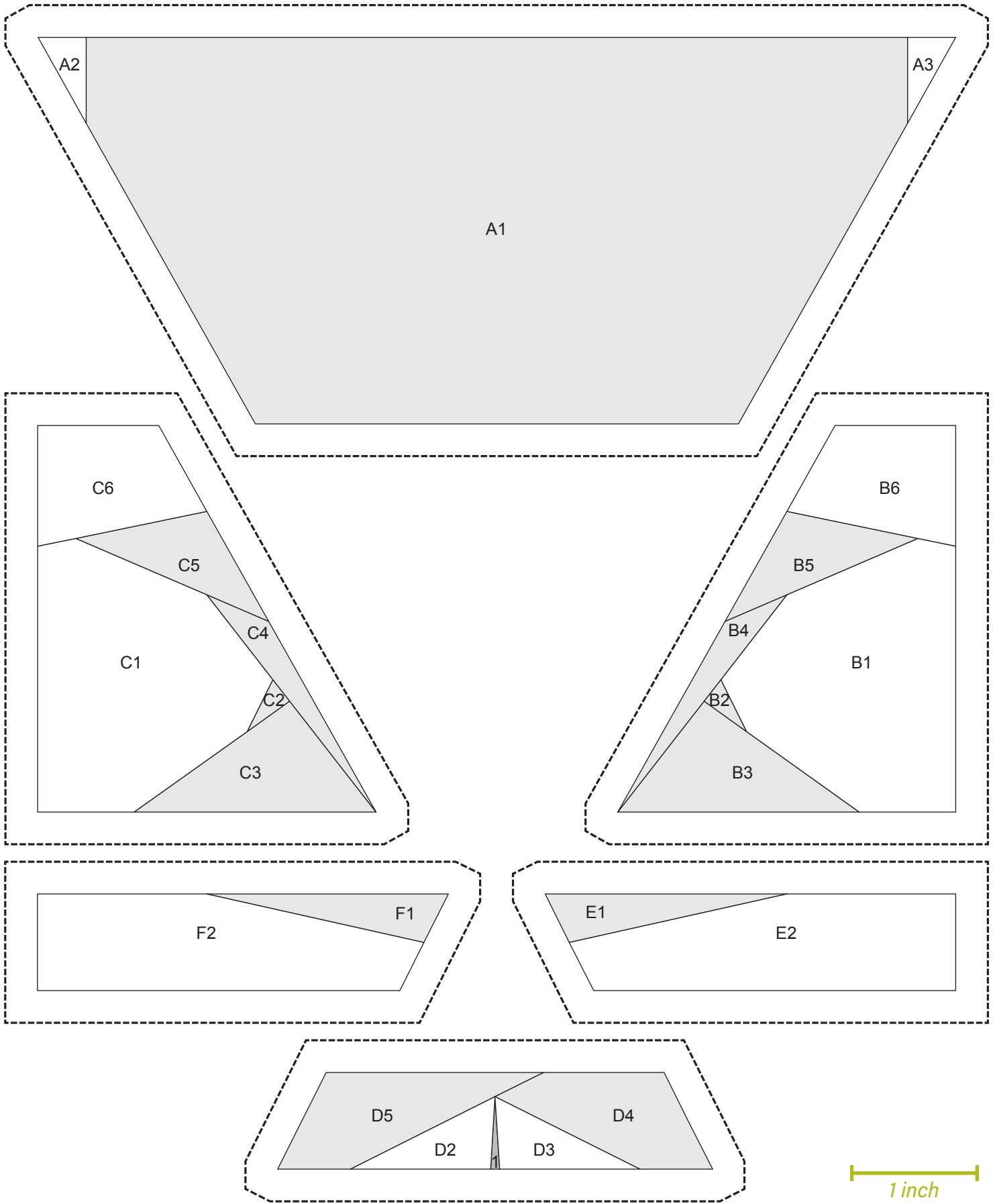
Fall Foliage Placemat Options & Coloring Page



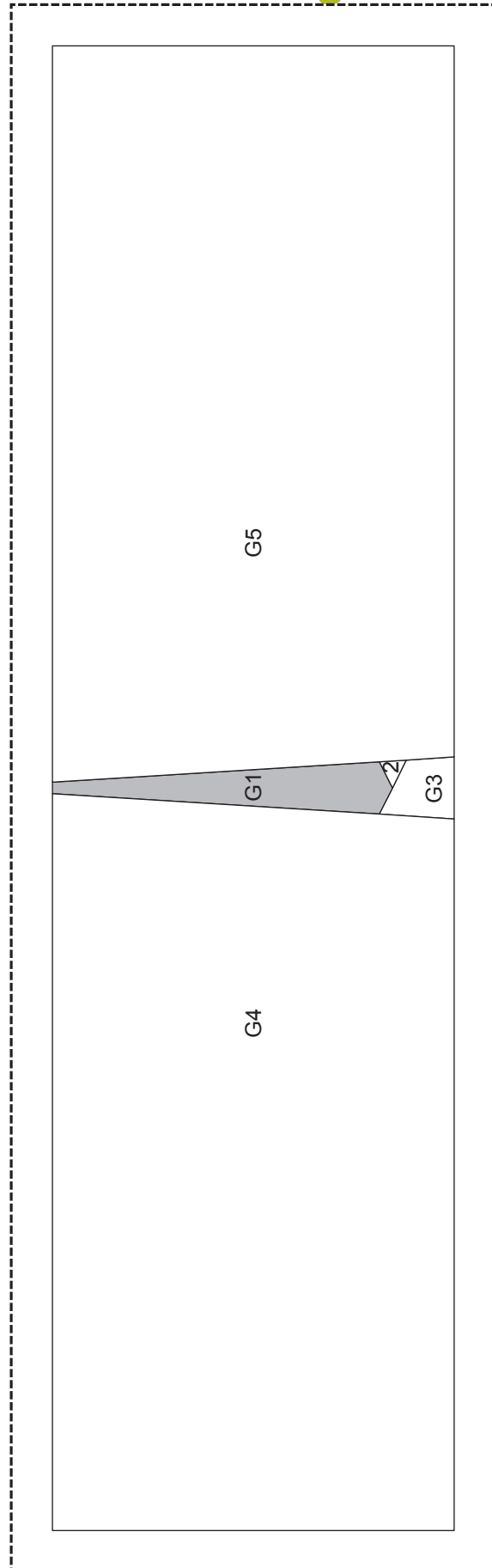
Fall Foliage Placemat - Sugar Maple Leaf



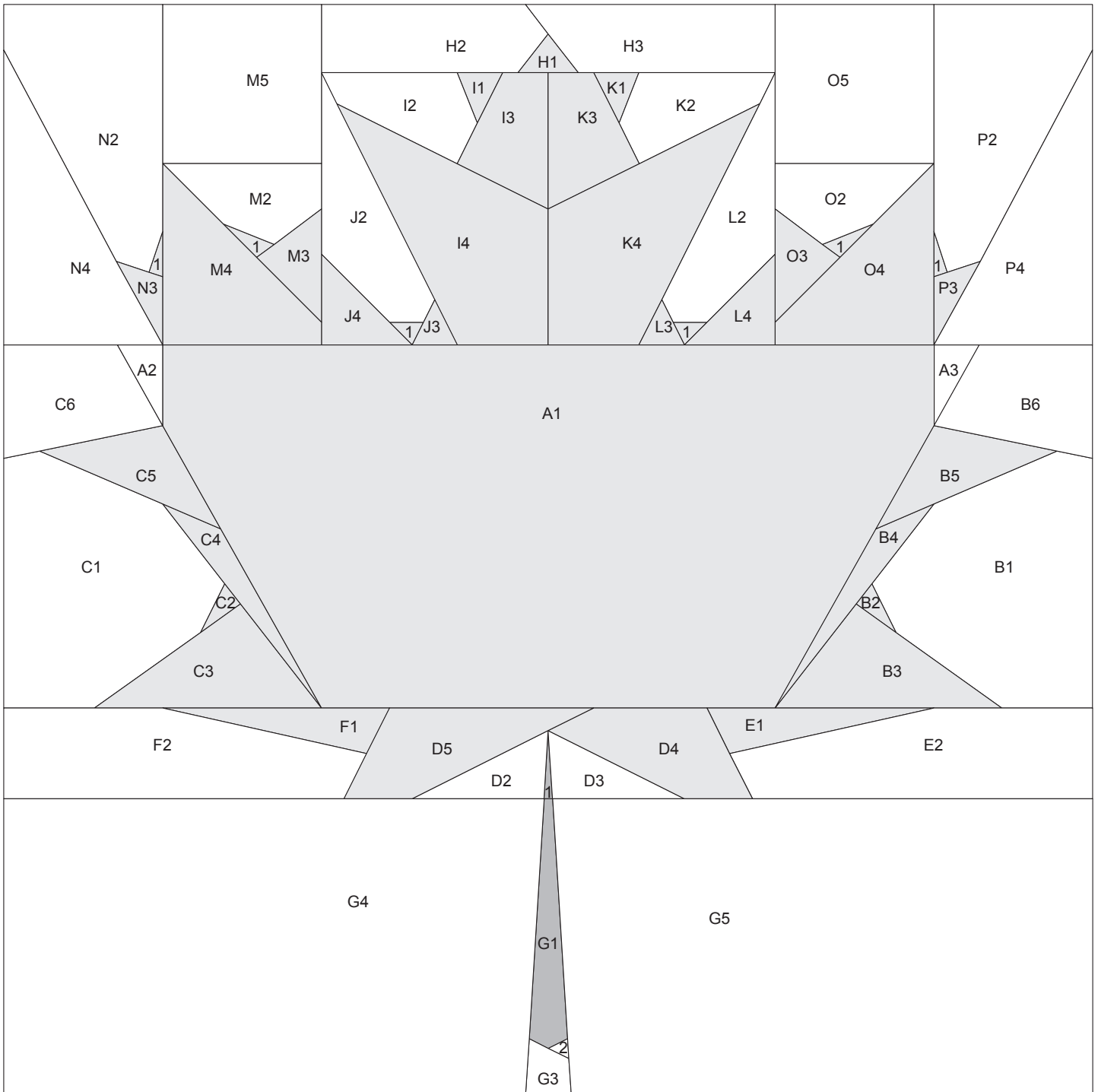
Fall Foliage Placemat - Sugar Maple Leaf



Fall Foliage Placemat - Sugar Maple Leaf Stem



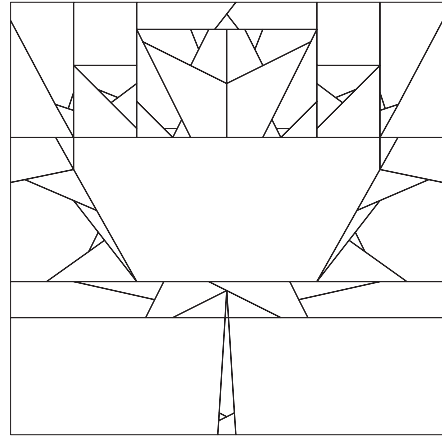
Fall Foliage Placemat - Sugar Maple Map



Color Key



Color Your Own



Assembly

The Sugar Maple Leaf (9" x 9" finished)

Before beginning, be sure to measure the 1" mark on pattern pages to ensure pattern was printed at full size. Sew each section individually. Press and trim each section prior to sewing sections together. See the block map for assembly assistance.

Middle of Block

Sew the angled side of B to the appropriate side of A, Sew C to the opposite side

Bottom of Block

Sew E to the side of D :: Sew F to the opposite side of D

Sew the top of G to the bottom of D/E/F

Top of Block

Sew I to J :: Sew K to L :: Sew I/J to K/L :: Sew the bottom of H to the top of I/J/K/L

Sew M to N :: Sew O to P

Sew M/N to H/I/J/K/L :: Sew O/P to the opposite side of H/I/J/K/L

To complete the block:

Sew A/B/C to the top of D/E/F/G :: Sew the top of A/B/C/D/E/F/G to the bottom of H/I/J/K/L/M/N/O/P

Press blocks when finished prior to trimming. Do not remove papers until the entire placemat top is finished.

Questions

If you are new to paper piecing, please see the next page for basic instructions and tips. Visit my website for additional tips and tricks.

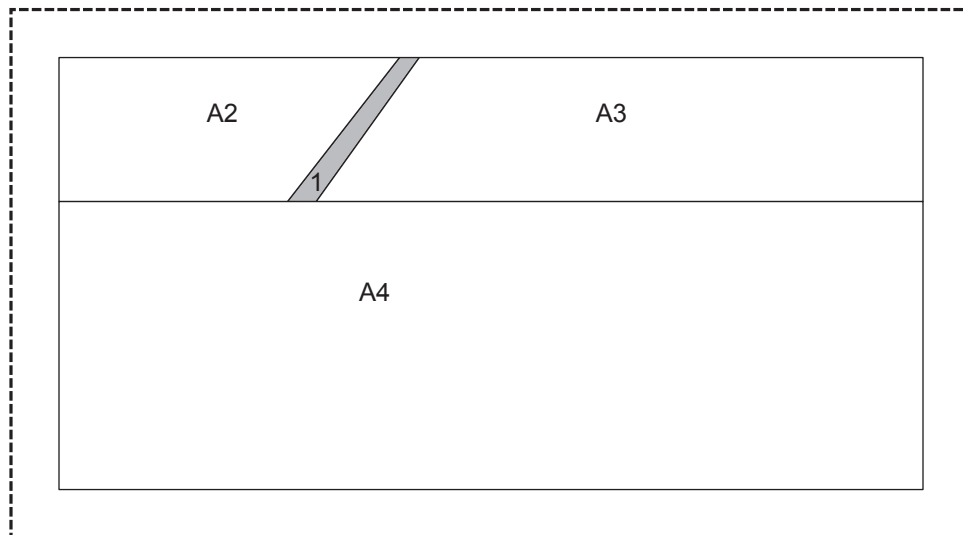
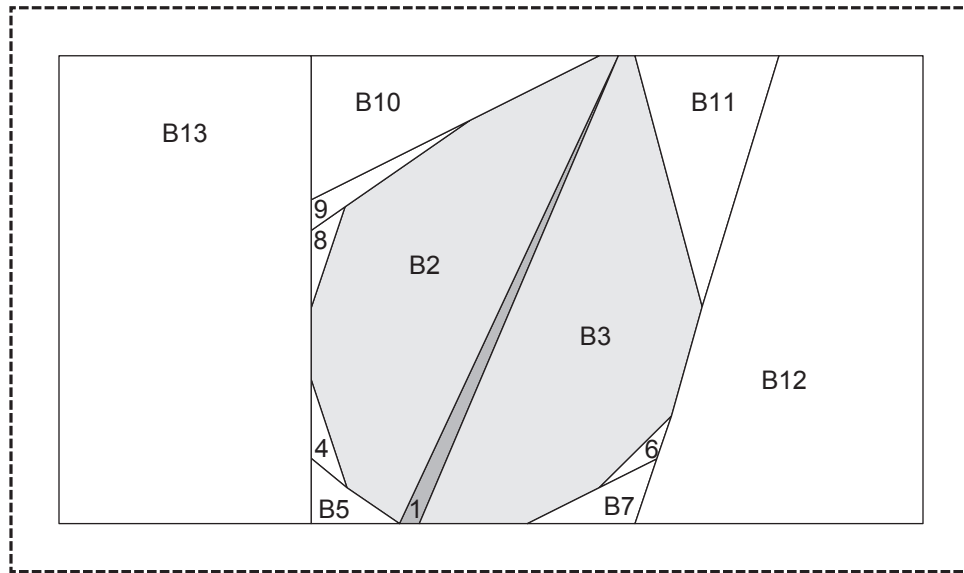
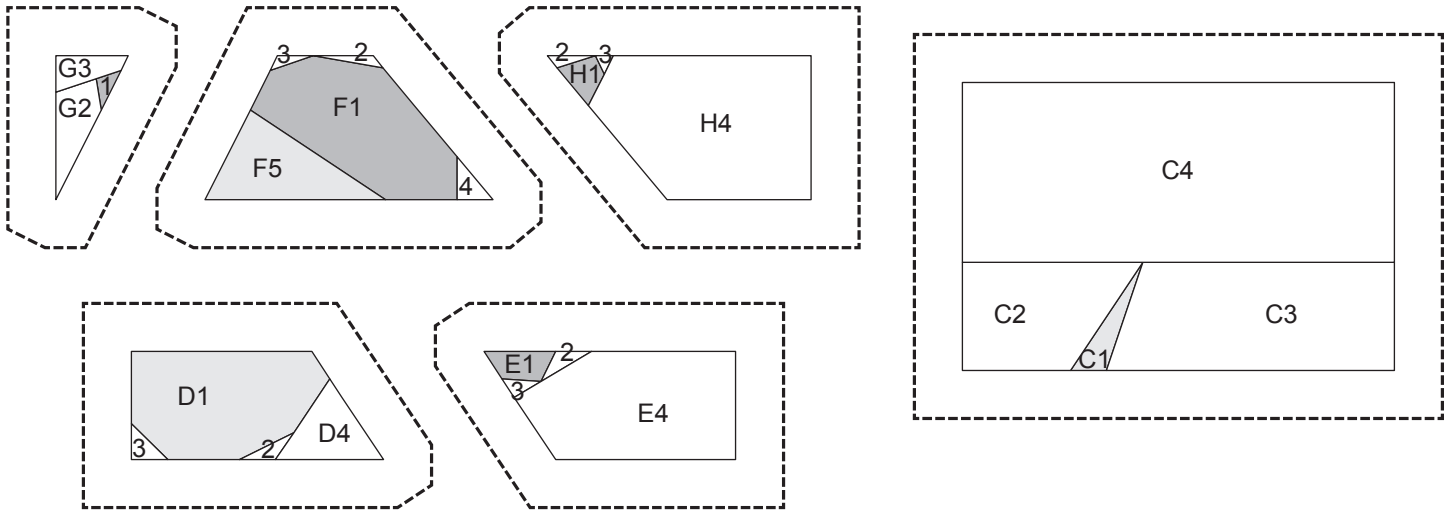
Legal Stuff

All designs (C) 2019 by Kid Giddy, 2 is Beautiful, LLC, Designed in EQ8 for BERNINA WeAllSew.com website.

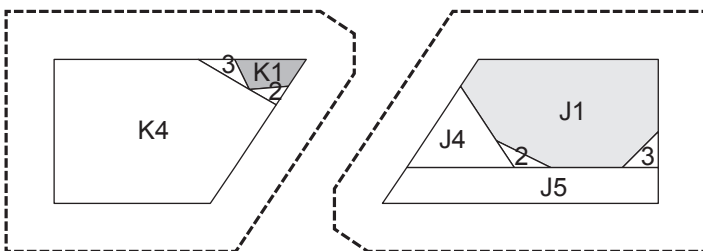
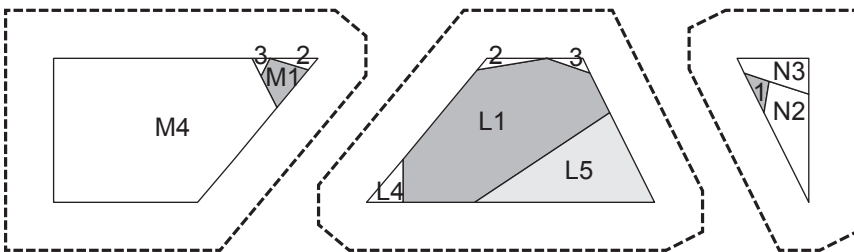
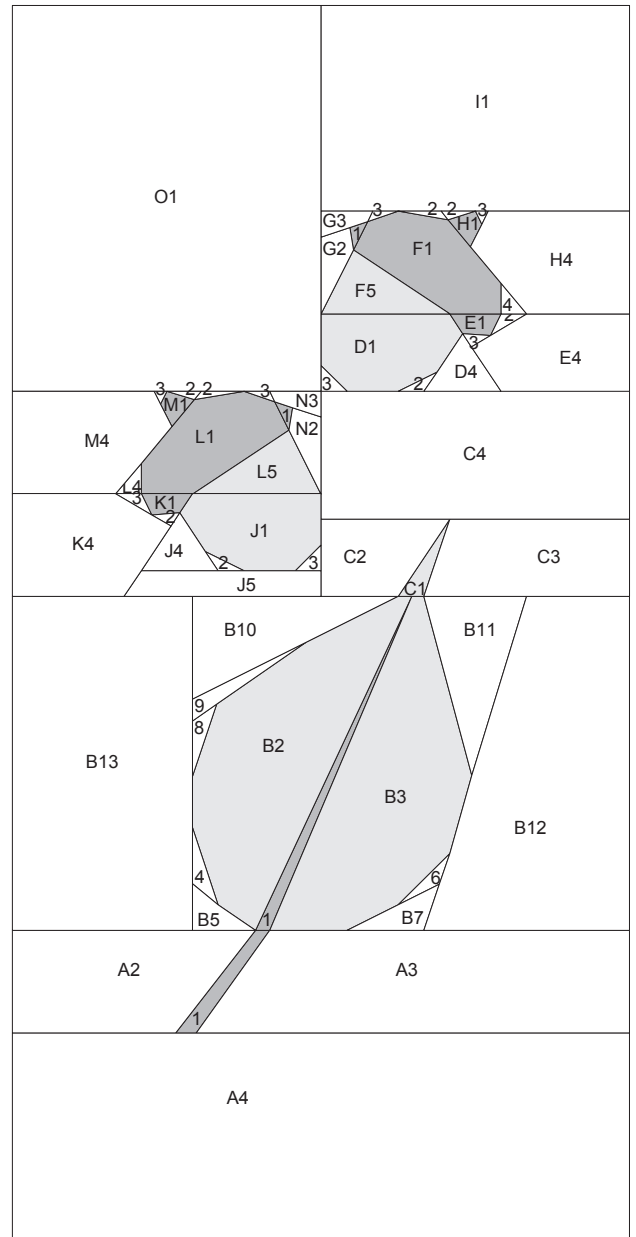
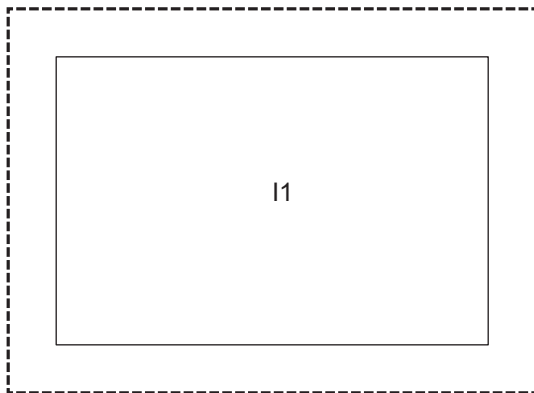
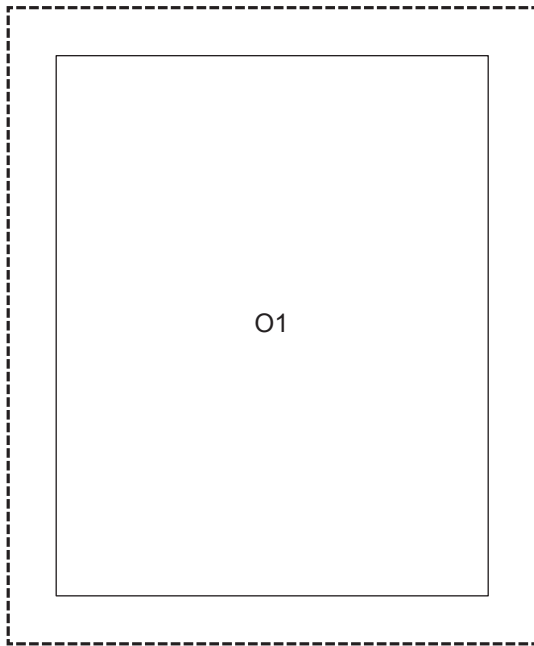
All rights reserved. This pattern may not be copied or reproduced in any form for classes, e-mailed to friends & family or for any other means, etc. The pattern or design may not be mass produced in any form without permission. Items cannot be reproduced in any quantity or style (including digitally) for commercial resale. You can sell handmade items made with this pattern in small quantities with permission if credit is included as follows: "Fall Foliage Placemat" pattern by Kerry Goulder (Kid Giddy)". #KidGiddy #FallFoliagePlacemat #WeAllSew #BERNINAUSA

Pattern for the "Fall Foliage Placemat" as 18½" x 11½" placemat // kidgiddy.com (C) 2019 by 2 is Beautiful, LLC

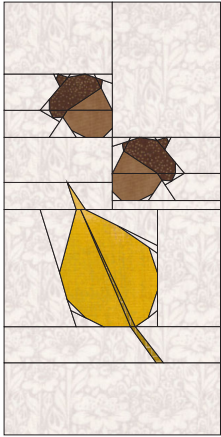
Fall Foliage Placemat - Beech Leaf & Acorns



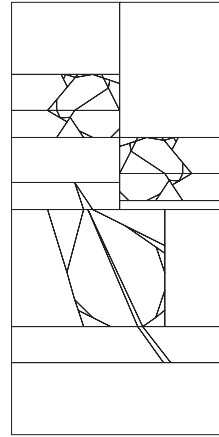
Fall Foliage Placemat - Beech Leaf & Acorns & Map



Color Key



Color Your Own



Assembly

The Beech Leaf and Acorns (4 ½" x 9" finished)

Before beginning, be sure to measure the 1" mark on pattern pages to ensure pattern was printed at full size. Sew each section individually. Press and trim each section prior to sewing sections together. See the block map for assembly assistance.

Sew the top of A to the bottom of B

Sew D to E :: Sew G to the corner of F :: Sew H to the opposite side of F

Sew the top of C to the bottom of D/E :: Sew the top of C/D/E to the bottom of F/G/H

Sew I to the top of C/D/E/F/G/H

Sew J to K :: Sew N to the corner of L :: Sew M to the opposite side of L

Sew the top of J/K to the bottom of L/M/N

Sew O to the top of J/K/L/M/N

To complete the block:

Sew C/D/E/F/G/H/I to J/K/L/M/N/O

Sew the top of A/B to the bottom of C/D/E/F/G/H/I/J/K/L/M/N/O

Press blocks when finished prior to trimming. Do not remove papers until the entire placemat top is finished.

Questions

If you are new to paper piecing, please see the next page for basic instructions and tips. Visit my website for additional tips and tricks. Online videos are also widely available.

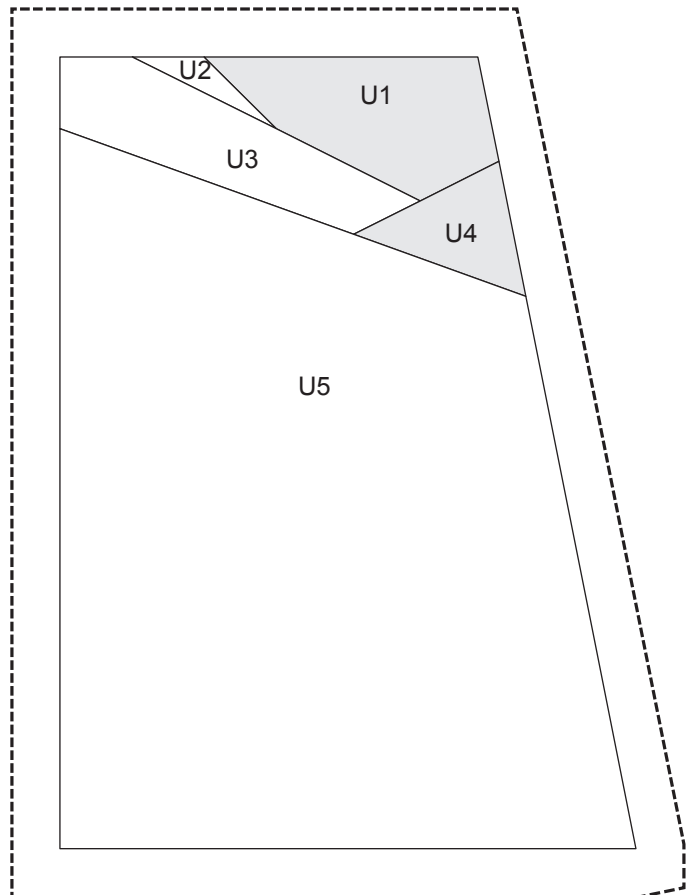
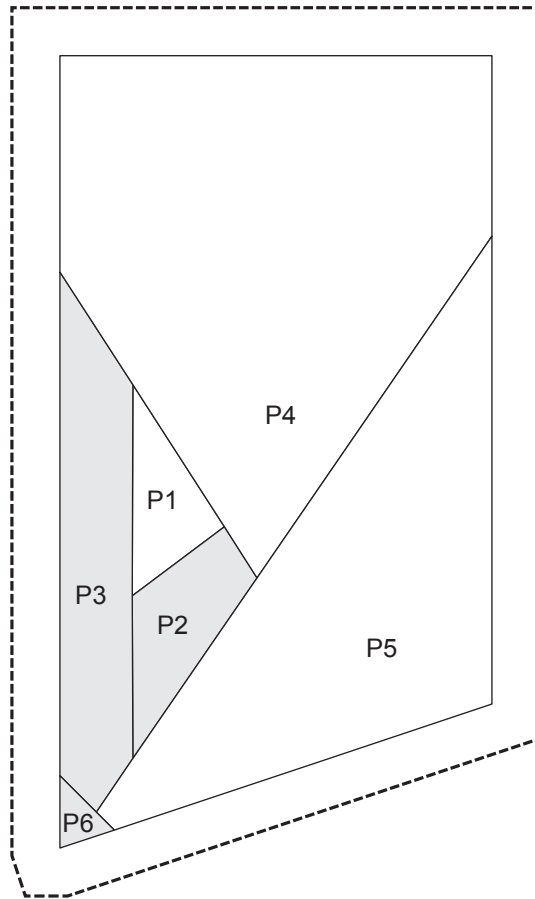
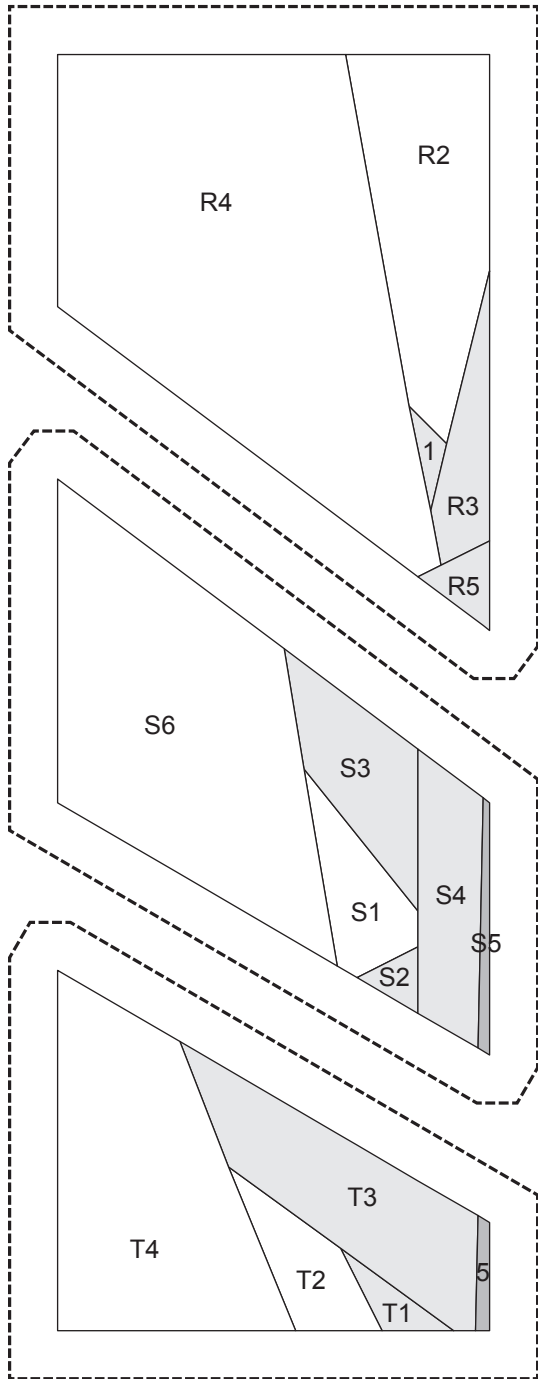
Legal Stuff

All designs (C) 2019 by Kid Giddy, 2 is Beautiful, LLC, Designed in EQ8 for BERNINA WeAllSew.com website.

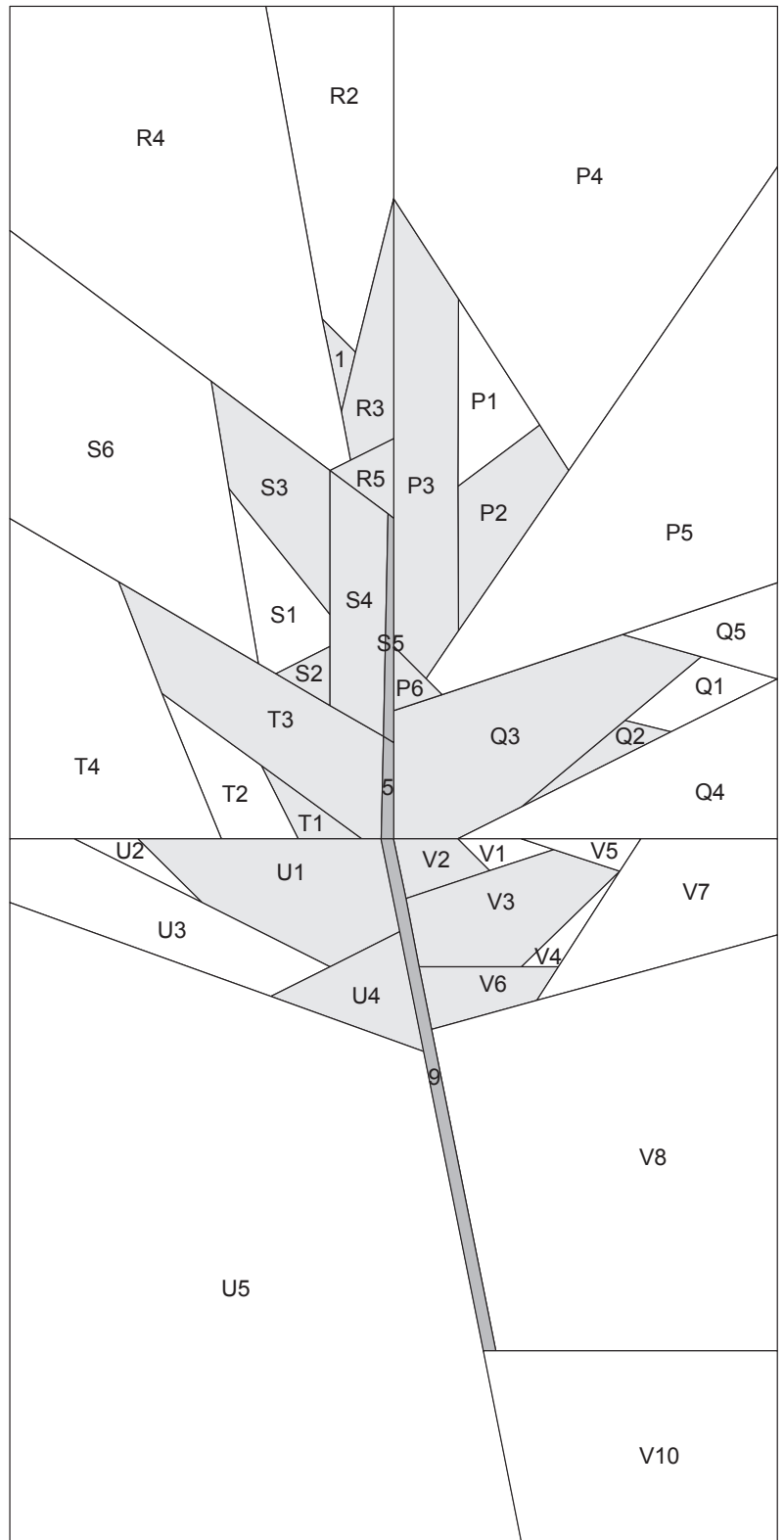
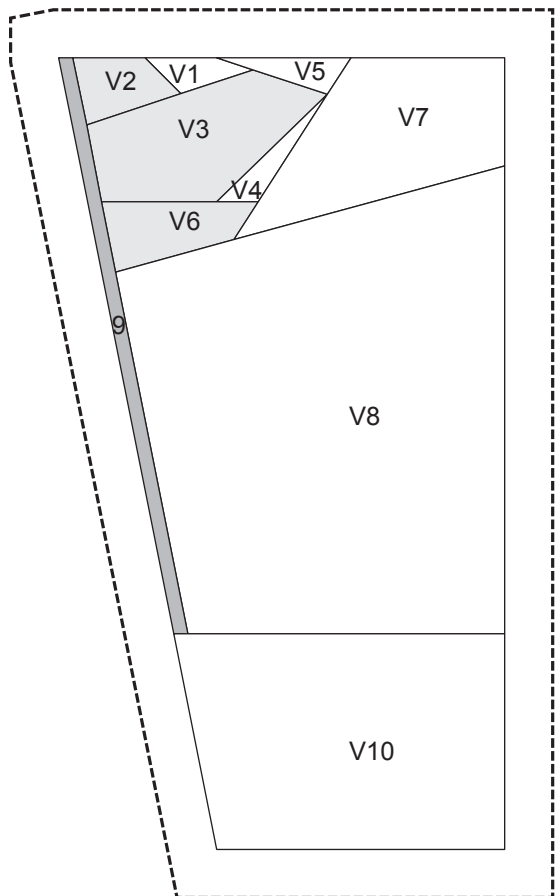
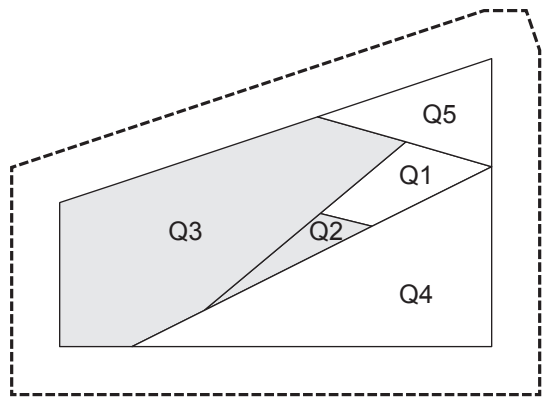
All rights reserved. This pattern may not be copied or reproduced in any form for classes, e-mailed to friends & family or for any other means, etc. The pattern or design may not be mass produced in any form without permission. Items cannot be reproduced in any quantity or style (including digitally) for commercial resale. You can sell handmade items made with this pattern in small quantities with permission if credit is included as follows: "Fall Foliage Placemat" pattern by Kerry Goulder (Kid Giddy)". #KidGiddy #FallFoliagePlacemat #WeAllSew #BERNINAUSA

Pattern for the "Fall Foliage Placemat" as 18½" x 11½" placemat // kidgiddy.com (C) 2019 by 2 is Beautiful, LLC

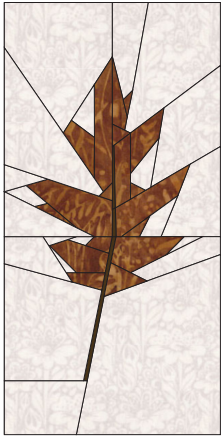
Fall Foliage Placemat - Oak Leaf



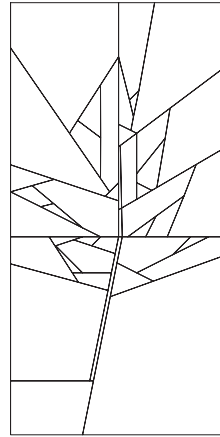
Fall Foliage Placemat - Oak Leaf & Map



Color Key



Color Your Own



Assembly

The Oak Leaf (4 ½" x 9" finished)

Before beginning, be sure to measure the 1" mark on pattern pages to ensure pattern was printed at full size. Sew each section individually. Press and trim each section prior to sewing sections together. See the block map for assembly assistance.

Sew P to the top of Q

Sew R to the top of S :: Sew R/S to the top of T

Sew P/Q to R/S/T

Sew U to V

To complete the block:

Sew P/Q/R/S/T to U/V

Press blocks when finished prior to trimming. Do not remove papers until the entire placemat top is finished.

Questions

If you are new to paper piecing, please see the next page for basic instructions and tips. Visit my website for additional tips and tricks.

Legal Stuff

All designs (C) 2019 by Kid Giddy, 2 is Beautiful, LLC, Designed in EQ8 for BERNINA WeAllSew.com website.

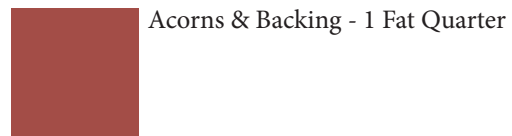
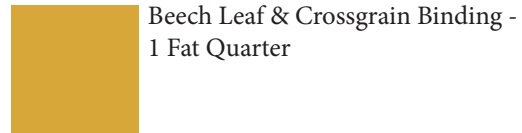
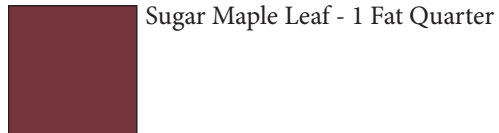
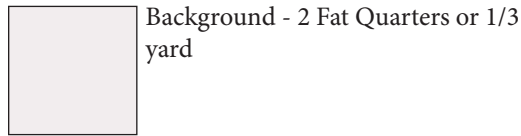
All rights reserved. This pattern may not be copied or reproduced in any form for classes, e-mailed to friends & family or for any other means, etc. The pattern or design may not be mass produced in any form without permission. Items cannot be reproduced in any quantity or style (including digitally) for commercial resale. You can sell handmade items made with this pattern in small quantities with permission if credit is included as follows: "Fall Foliage Placemat" pattern by Kerry Goulder (Kid Giddy)". #KidGiddy #FallFoliagePlacemat #WeAllSew #BERNINAUSA

Pattern for the "Fall Foliage Placemat" as 18½" x 11½" placemat // kidgiddy.com (C) 2019 by 2 is Beautiful, LLC

Fabric Requirements for Placemat & Swatch Page

Yardage estimate is based on 42" WOF and do not include fabric requirements for all options. Yardage is based on the entire placemat being completed with all three designed blocks.

*(more fabric is required if fussy cutting or print is directional). Use the similar colors and place swatches on squares with your own fabric pieces for reference.



Fall Foliage Placemat 18 1/2" x 11 1/2"

As soon as summer comes to an end, the leaves begin falling from every nearby tree signaling that time for gratitude, family and friends. It is a time when we gather together around a warm and delish table or walk together enjoying the crisp air, finding the crunchiest leaves blowing along the street.

This placemat celebrates the beauty of those falling leaves and the gathering to come of family and friends, neighbors and even strangers. Make just one for the turkey or pumpkin pie, or one for every place setting. Get cozy with your machine and make a table runner to match too. Happy and warm sewing.

Share your finished pictures on Instagram, Facebook, & Twitter - tagging me: @kidgiddy and using hashtags: #kidgiddy #FallFoliagePlacemat



Pattern Design (in EQ8) for BERNINA WeAllSew.com
Illustrations/Photos by Kerry Goulder

Fabric Requirements for Fall Foliage Placemat*

Fall Foliage Placemat (18.5" w x 11.5" h finished) - This Fall Foliage Placemat can be tailored to your own desires by using a just one block, two or all three. You can change the size of your placemat by altering the sashing and border widths as well. The following requirements are general guidelines for the placemats but do not include fabric requirements for the suggested Table Runner pattern provided.

Background	1 print = 2 Fat Quarter or 1/3 Yard
Sugar Maple Leaf block	1 print = 1 Fat Quarter
Oak Leaf	1 print = 1 Fat Eighth
Acorn Tops & Stems	1 print = 5" x 10"
Beech Leaf &	1 print = 1 Fat Quarter
Crossgrain Binding	
Acorns & Backing	1 Fat Quarter
Batting	1 piece 20" x 13"

*When selecting fabric, consider purchasing more than recommended if using directional prints.

Additional Supplies

Rotary cutter, cutting mat, a 24" quilting ruler for trimming the blocks and placemat, mini iron, washable glue for basting, (starch as desired), straight pins or clips, sharp angled tweezers, sewing machine, thread snips.

+ Swatch page included for reference.

All designs (C) 2019 by Kid Giddy, 2 is Beautiful, LLC.

All rights reserved. This pattern may not be copied or reproduced in any form for classes, emailed to friends & family or for any other means, etc. It may not be mass produced in any form without permission. You can sell items made with this pattern in small quantities if credit is included as follows: "Fall Foliage Placemat" pattern by Kerry Goulder (Kid Giddy)". Items made cannot be reproduced in any quantity for commercial resale.

Kid Giddy